

3538^{-20/02}
^{-30/02}

INSTRUCTION MANUAL

This instruction manual applies to machines
from the following serial numbers onwards: 2 804 345
and software version 0437/001.



This instruction manual applies to all models and subclasses listed in Chapter 3 Technical Data.



The adjustment manual for the machine can be downloaded at no charge under www.pfaff-industrial.de/de/service-support/downloads/technical.
As an alternative to the Internet download, the adjustment manual can also be ordered under order no. **296-12-19 293/002**.

Reprinting, reproduction and/or translation of PFAFF instruction manuals (including parts thereof) is only permitted with our prior agreement and citation of the source.

**PFAFF Industriesysteme
und Maschinen GmbH**

Hans-Geiger-Str. 12 - IG Nord
D-67661 Kaiserslautern

	Contents	Page
1	Safety	5
1.01	Directives	5
1.02	General safety instructions	5
1.03	Safety symbols	6
1.04	Special points of attention for the owner-operator	6
1.05	Operating personnel and technical staff	7
1.05.01	Operating personnel	7
1.05.02	Technical staff.....	7
1.06	Danger warnings.....	8
2	Proper Use.....	9
3	Technical Data[▲]	10
3.01	PFAFF 3538	10
4	Disposal of the Machine.....	11
5	Transport, Packaging and Storage	12
5.01	Transport to the customer's premises	12
5.02	Transport within the customer's premises.....	12
5.03	Disposal of the packaging materials	12
5.04	Storage	12
6	Work Symbols.....	13
7	Operating Controls	14
7.01	Main switch	14
7.02	Light barrier.....	14
7.03	Stop button	15
7.03a	Loader	15
7.04	Control panel.....	16
7.04.01	Symbols on the display.....	17
7.04.02	Plus/minus keys.....	17
7.04.03	Function keys.....	18
8	Set-up and Initial Commissioning	20
8.01	Set-up	20
8.01.01	Aligning the machine	20
8.01.02	Mounting the reel stand	21
8.02	Connecting the plug-in connections and ground cable	22
8.03	Initial start-up	23

Table of Contents

	Contents	Page
8.04	Switching the machine on/off	23
9	Set-up.....	24
9.01	Inserting the needle.....	24
9.02	Threading the needle / adjusting the needle thread	25
10	Input.....	26
10.01	Sewing – automatic mode	27
10.02	Sewing – Unit with cutter and rack.....	28
10.03	Input mode	29
10.04	Input mode	31
10.09	Parameter list.....	32
10.10	Error messages.....	36
11	Maintenance and Care.....	38
11.01	Maintenance intervals.....	38
11.02	Cleaning the machine	38
11.03	Checking / topping up the oil level of the oil tank for the front parts.....	39
11.04	Checking / topping up the oil level of the gear mechanism.....	40
11.05	Checking / setting the air pressure	41
11.06	Emptying / cleaning the maintenance unit’s water tank.....	41
12	Wearing Parts.....	42

1 Safety

1.01 Directives

The machine was built in compliance with the European regulations specified in the declaration of conformity and declaration of incorporation.

As a supplement to this instruction manual, please also observe the generally applicable, legal and other regulations and legislation – also in the country of use – and the valid environmental protection regulations! Always comply with the locally applicable regulations of the professional associations and other supervisory authorities!

1.02 General safety instructions

- The machine may only be operated after you have become acquainted with the associated instruction manual and only by operating personnel who have received appropriate training!
- Always read the safety instructions and the instruction manual of the motor manufacturer before starting up the machine!
- Always follow the hazard and safety instructions attached to the machine!
- The machine may only be operated for its intended purpose and only with the associated safety covers, while adhering to all the relevant safety requirements.
- The machine must always be disconnected from the power supply by pressing the main switch or pulling out the mains plug when sewing tools are replaced (such as the needle, sewing foot, needle plate, feed dog etc.) and when threading, leaving the workstation, or performing maintenance!
- The daily maintenance work may only be carried out by suitably qualified personnel!
- Repairs and special maintenance work may only be carried out by technical staff or people with appropriate training!
- Unless otherwise stated, the machine must be isolated from the power supply and pneumatic supplies before any servicing work or repairs are performed! The only permitted exceptions are for adjustment work and functional tests by appropriately trained technical staff!
- Work on electrical equipment may only be carried out by qualified technical staff!
- Work on parts and equipment under voltage is not permitted!
Exceptions are regulated by the EN 50110 standards.
- Modifications and changes to the machine may only be made in compliance with all of the relevant safety requirements!
- Only those replacement parts approved by us for usage may be used for repairs! We warn you expressly that spare parts and accessories that are not supplied by us are also not tested and approved by us.
Fitting or using these products may therefore have negative effects on features which depend on the machine design. We are not liable for any damage caused by the use of non-Pfaff parts.

1.03 Safety symbols



Hazard point!
Special points of attention.



Risk of injury to operating personnel or technical staff!



Electric voltage!
Danger to operating personnel or technical staff.



Danger of hands being crushed!



Caution!

Do not operate without finger guard and safety covers!
Turn off the main switch before threading, changing the bobbin or needle, cleaning etc!

1.04 Special points of attention for the owner-operator

- This instruction manual is a part of the machine and must be made available to the operating personnel at all times. The instruction manual must have been read before the initial start-up.
- The operating personnel and technical staff must be instructed about the machine's safety covers and about safe working methods.
- The owner-operator may only operate the machine in a flawless condition.
- The owner-operator must ensure that no safety covers are removed or disabled.
- The owner-operator must ensure that only authorised persons work on the machine.

Additional information can be requested from the responsible sales centre.

1.05 Operating personnel and technical staff

1.05.01 Operating personnel

Operating personnel are persons responsible for equipping, operating and cleaning the machine and for fault clearance in the sewing area.

The operating personnel are obligated to comply with the following points:

- The safety instructions provided in the instruction manual must be followed for all work!
- Any work method jeopardising machine safety must be refrained from!
- Tight-fitting clothing must be worn. The wearing of jewellery such as chains and rings is prohibited!
- Care must be taken to ensure that no unauthorised persons are located in the machine's hazard zone!
- Any changes occurring on the machine which impair its safety must be reported to the owner-operator immediately!

1.05.02 Technical staff

Technical staff are persons with technical training in electricity/electronics and mechanics. They are responsible for lubricating, servicing, repairing and adjusting the machine.

The technical staff are obligated to comply with the following points:

- The safety instructions provided in the instruction manual must be followed for all work!
- Turn off the main switch before starting any adjustment or repair work and secure it against reactivation!
- Working on live parts and equipment is prohibited!
Exceptions are regulated by the EN **50110** standards.
- Unless otherwise stated, the machine must be isolated from the power supply and pneumatic supplies before any servicing work or repairs are performed!
Exceptions are permitted solely for function tests.
- Reattach the safety covers following repair and maintenance work!

1.06

Danger warnings



A work area of **1 m** must be kept around the machine during operation to ensure unobstructed access at all times.



Do not reach into the needle range during the sewing operation!
Risk of injury from the needle!



Do not allow any objects to be placed on the table during the adjustment work!
The objects could become jammed or be slung away!
Risk of injury from parts flying around!



Danger of hands being crushed!

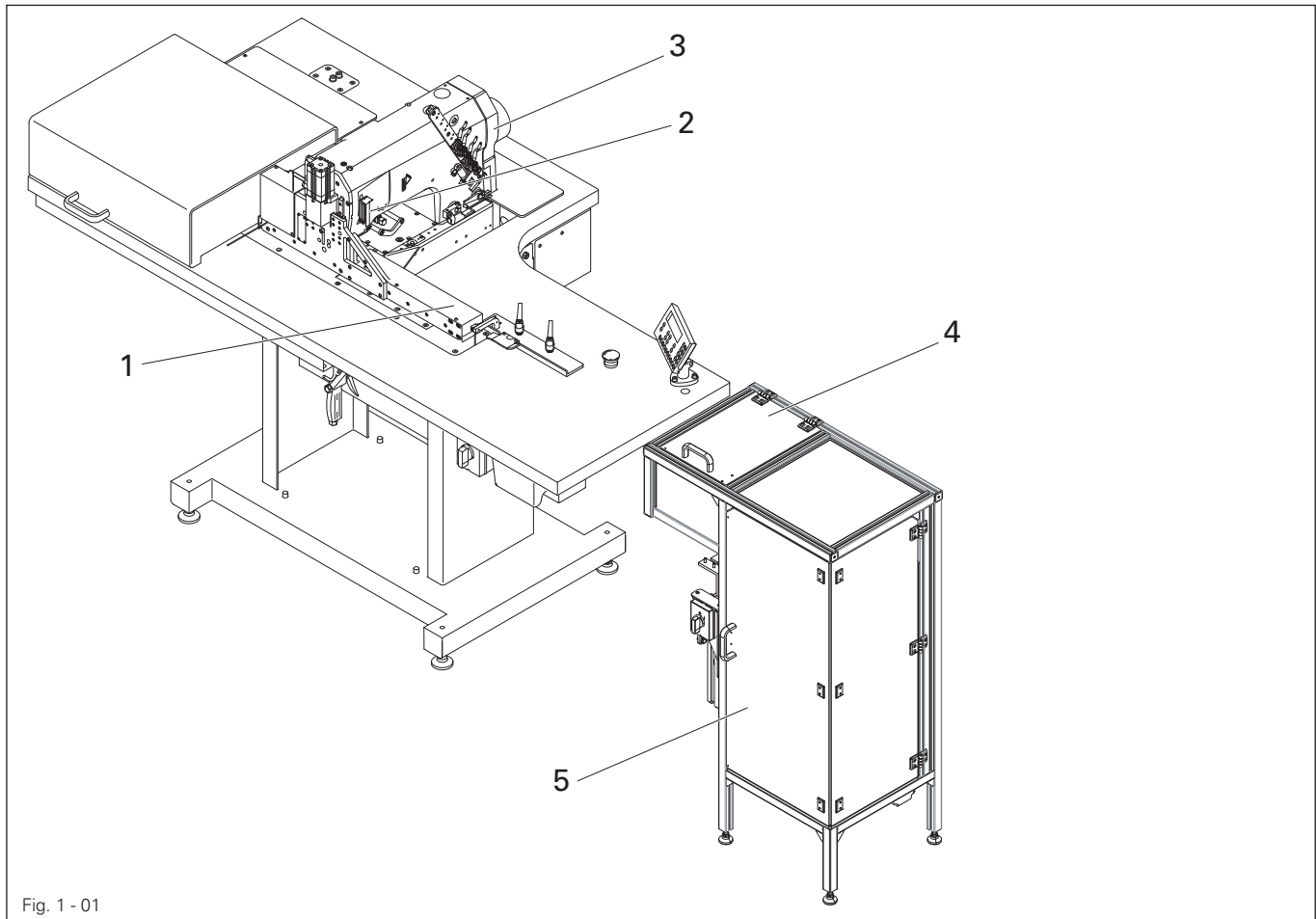

Fig. 1 - 01



Do not operate the machine without the protective cover **1!**
Risk of injury from the feed band!



Do not operate the machine without the take-up lever guard **2!**
Risk of injury due to movement of the take-up lever!



Do not operate the machine without the belt guard **3!**
Risk of injury due to the rotating driving belt!



Only operate the charging station with the protective cover **4** and door **5** closed!
Charging station does not start otherwise!

2 **Proper Use**

The PFAFF 3538 is a sewing machine for efficiently hemming pocket openings.



Any usage not approved by the manufacturer is deemed misuse! The manufacturer shall assume no liability for damage caused by misuse! Proper use also includes compliance with the operating, maintenance, adjustment and repair measures specified by the manufacturer!

3 Technical Data▲

3.01 PFAFF 3538

Stitch type:.....401 (chainstitch)

Design B: for the machining of medium-weight materials

Design C: for the machining of medium-heavy materials

Needle thickness: 80 – 140

Needle system:..... 62x57

Thread thickness max..... 11/3

Speed max.:..... 4000 stitches/min.

Stitch length max:.....4.5 mm

Noise data:

Noise emission level at workplace with a sewing speed of $n = 2400 \text{ min}^{-1}$: $L_{pA} = 75 \text{ dB(A)}$

(Noise measurement in accordance with DIN 45 635-48-A-1, ISO 11204, ISO 3744, ISO 4871)

Motor data: see motor instruction manual

Air consumption per switching cycle:.....0.146 NI

Net weight of sewing head with stand:..... approx. 308 kg

Gross weight of sewing head with stand: approx. 521 kg

▲ Subject to alterations

■ $K_{pA} = 2.5 \text{ dB}$

4

Disposal of the Machine

- It is up to the customer to dispose of the machine properly.
- The materials used for the machine include steel, aluminium, brass and various plastics. The electrical equipment consists of plastics and copper.
- The machine must be disposed of in accordance with the locally valid environmental protection regulations, with a specialised company being contracted if necessary.



Please ensure that parts coated with lubricants are disposed of separately in accordance with the locally valid environmental protection regulations!

5 Transport, Packaging and Storage

5.01 Transport to the customer's premises

All machines are completely packed for delivery.

5.02 Transport within the customer's premises

The manufacturer assumes no liability for transport within the customer's premises or to the individual usage sites. Please ensure that the machines are only transported in a vertical position.

5.03 Disposal of the packaging materials

The packaging materials of these machines consists of paper, cardboard and VCI fleece. It is up to the customer to dispose of the packaging properly.

5.04 Storage

The machine can be stored for up to **6** months when not in use. It must then be protected from dirt and moisture. For longer storage periods, the machine's single components, especially its sliding surfaces, must be protected against corrosion, e.g. by an oil film.

6 Work Symbols

Activities to be performed or important information in this instruction manual are emphasised by symbols. The symbols used have the following meaning:



Note, information



Cleaning, care



Lubrication

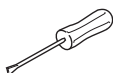

Maintenance, repairs, adjustment, service work
(only to be carried out by technical staff)

7 Operating Controls

7.01 Main switch

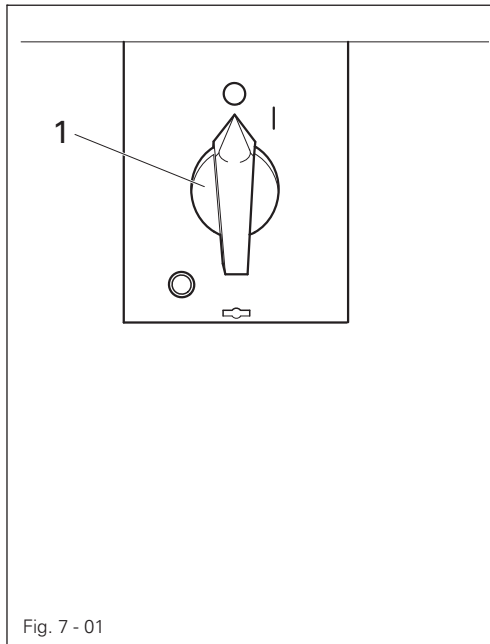

- Turning the main switch 1 switches the machine on and off.

7.02 Light barrier

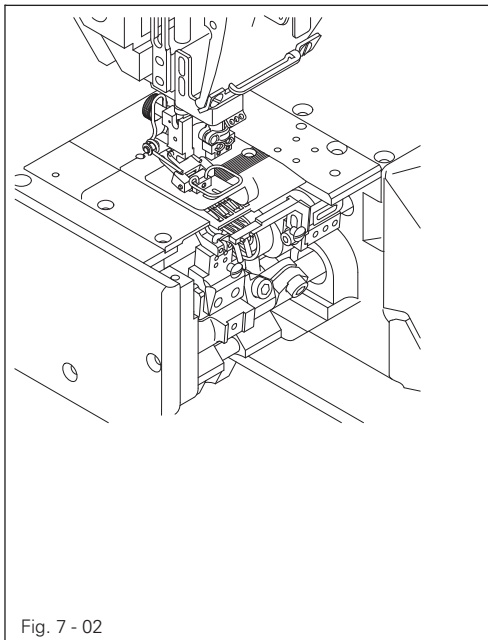

- The LED in the light barrier indicates the following status:
 - LED lights up green = Reception indicator (If there is no sewing material below it).
 - LED flashes green or yellow = Setting aid/soiling indicator.
 - LED lights up yellow = Output indicator (if there is no sewing material below it).

7.03 Stop button

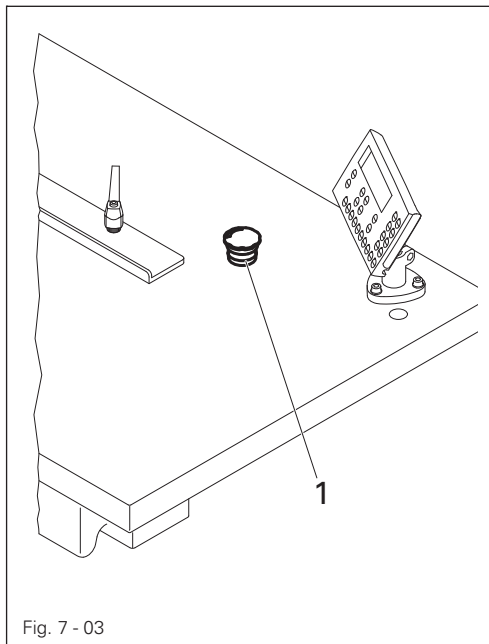

- Press the stop button:
Machine and feed band stop.
- Release the stop button:
Press the F4 key on the control panel to start the machine or insert new pocket blanks.

7.03a Loader

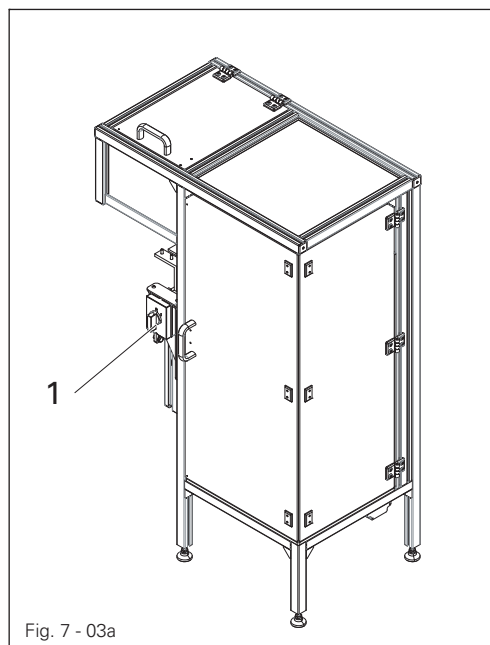

- Turning the main switch 1, the charging station is switched on or off.

7.04 Control panel

The control panel is used to display and access machine functions for set-up and sewing, to enter parameter values and to read error messages and service settings.

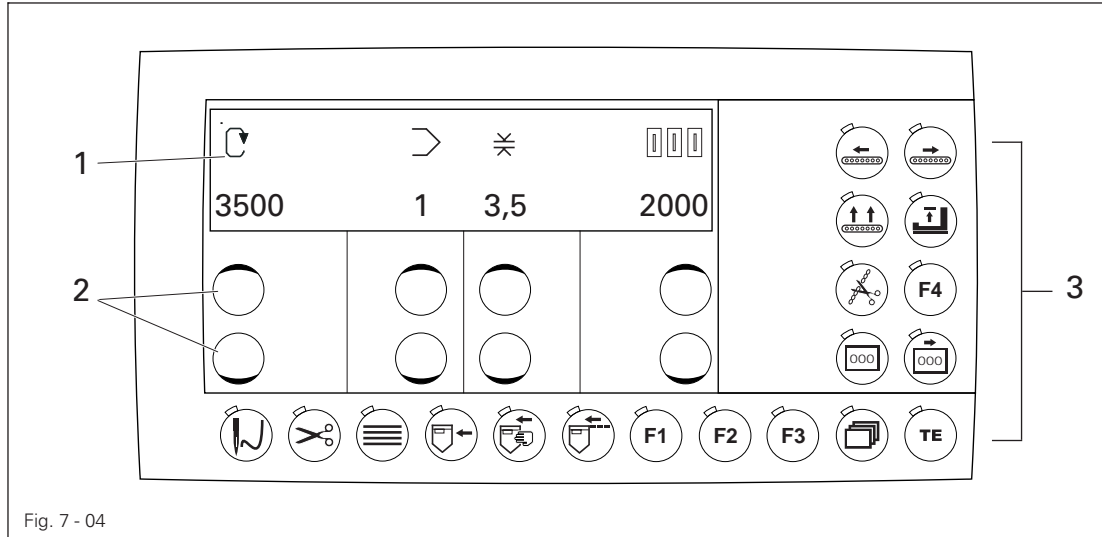

Fig. 7 - 04

The control panel has the following operating and display controls:

- The display 1 comprises a two-line alphanumeric LCD display with 16 characters per line and is used to display the corresponding information and selection parameters.
- The plus/minus keys 2 are used for selecting or altering the functions and parameters shown on the display.
- The function keys 3 are used for turning the corresponding function on and off. Switched-on functions are each indicated by the lit LED.

7.04.01 Symbols on the display

In addition to clear texts and set values, the following symbols appear on the display.

Symbol	Function
>	Current program number
□□□□	Piece counter
⌚	Speed
✖	Stitch length
□	SD memory card
□	Machine memory
↵	Enter

7.04.02 Plus/minus keys

The corresponding set values are selected and altered using the appropriate plus-minus keys. At the same time the set value shown above is changed slowly at first by pressing and holding the corresponding plus or minus key. If the key is held pressed for longer, the set value changes more quickly.

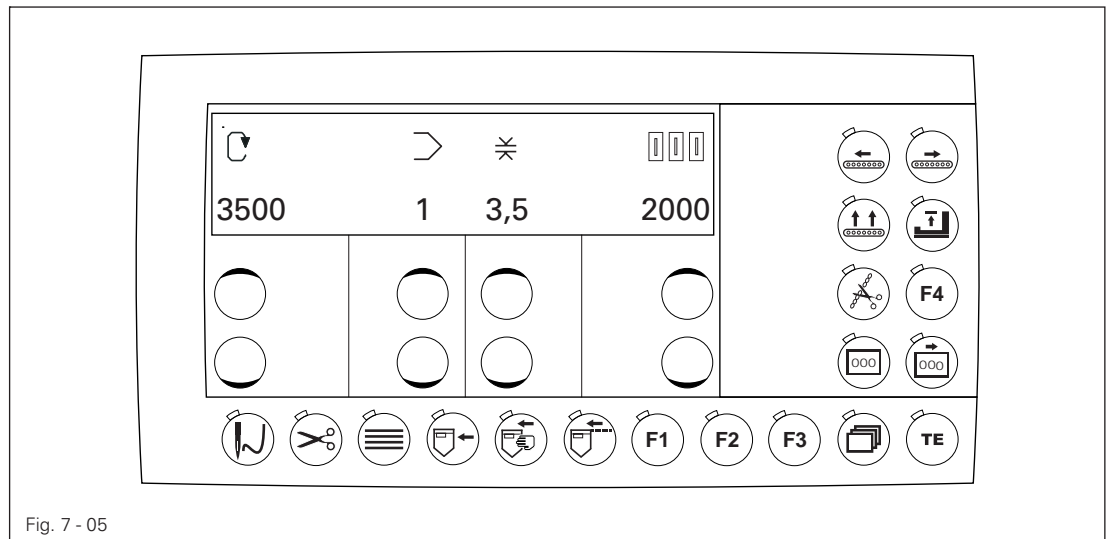

Fig. 7 - 05



Plus/minus keys

The displayed values can be increased or decreased using the respective key on the display

7.04.03 Function keys

If a function is on, this is always indicated by the correspondingly lit LED. Detailed explanation of functions:



● Thread machine

The sewing head is moved back so that the machine can be threaded.

The thread tension is opened when threading.

This key corresponds to number **1** when entering the code number.



● Chain cutter on/off (with subclasses **2** and **3**).

The chain is separated at the start and end of the pocket during the sewing operation.

This key corresponds to number **2** when entering the code number.



● Stacker on/off (with subclass **3**)

The sewn pockets are automatically stacked during the sewing operation if the cover of the stacker is closed.

This key corresponds to number **3** when entering the code number.



● Label feeder on/off (with subclass **4**).

This key corresponds to number **4** when entering the code number.



● Fill the unit

The unit is filled after pressing the key. **FILL 3538** appears on the display.

Now pocket blanks must be fed in until the unit is completely filled. The unit is filled when the length entered in parameter **503** is reached. If the unit is filled, it automatically switches to the sewing operation.

This key corresponds to number **5** when entering the code number.



● Sew until the unit is empty (with subclasses **2** and **3**)

The unit sews until all pocket blanks are sewn after pressing the key.

EMPTY 3538 appears on the display. The unit automatically switches to ready for sewing when the unit sews until it is empty.

This key corresponds to number **6** when entering the code number.



● F1 key

This key is reserved for special functions.

This key corresponds to number **7** when entering the code number.



● F2 key

This key is reserved for special functions.









This key corresponds to number **8** when entering the code number.



● F3 key

This key is reserved for special functions.

This key corresponds to number **9** when entering the code number.

-  ● F4 key
The unit continues to sew after the "Remove fabric" message although there is still material under the initial light barrier.
-  ● Scroll
If this key is pressed, the input menus on the display are scrolled through.
-  ● TE key
The machine changes from sewing mode to stitch input mode if this key is pressed.
-  ● Piece counter / counter
These keys can be used to switch between the piece counter and the counter. If the respective function is switched on, a menu appears to set the counter to a preset, variable value when pressing the key.
Coded via parameters **811** and **812**.
The piece counter key corresponds to number **0** when entering the code number.
-  ● Separate chain (with subclasses **2** and **3**)
The chain cutter is activated once after pressing the key.
-  ● Raise/lower band feed
This is raised if the band feed is lowered and lowered if the band feed is raised. Coded via parameter **813**.
-  ● Raise/lower presser foot
This is raised if the presser foot is lowered and lowered if the presser foot is raised. Coded via parameter **813**.
-  ● Band feed forwards
The band feed moves forward while the key is pressed.
Coded via parameter **813**.
-  ● Band feed backwards
If the band feed is raised, the band feed moves backwards while the key is pressed.
Coded via parameter **813**.

8 Set-up and Initial Commissioning



The machine may only be set up and started up by qualified personnel! All of the relevant safety regulations must always be complied with in this process! Adequate stability of the stand must be guaranteed, even during the sewing operations.

8.01 Set-up

Suitable electrical and pneumatic supply connections must be provided at the erection site, see **Chapter 3 Technical Data**.

The erection site must have a firm and level subsurface and adequate lighting.



The table top is lowered for packaging purposes.
The adjustment of the table height is described below.

8.01.01 Aligning the machine

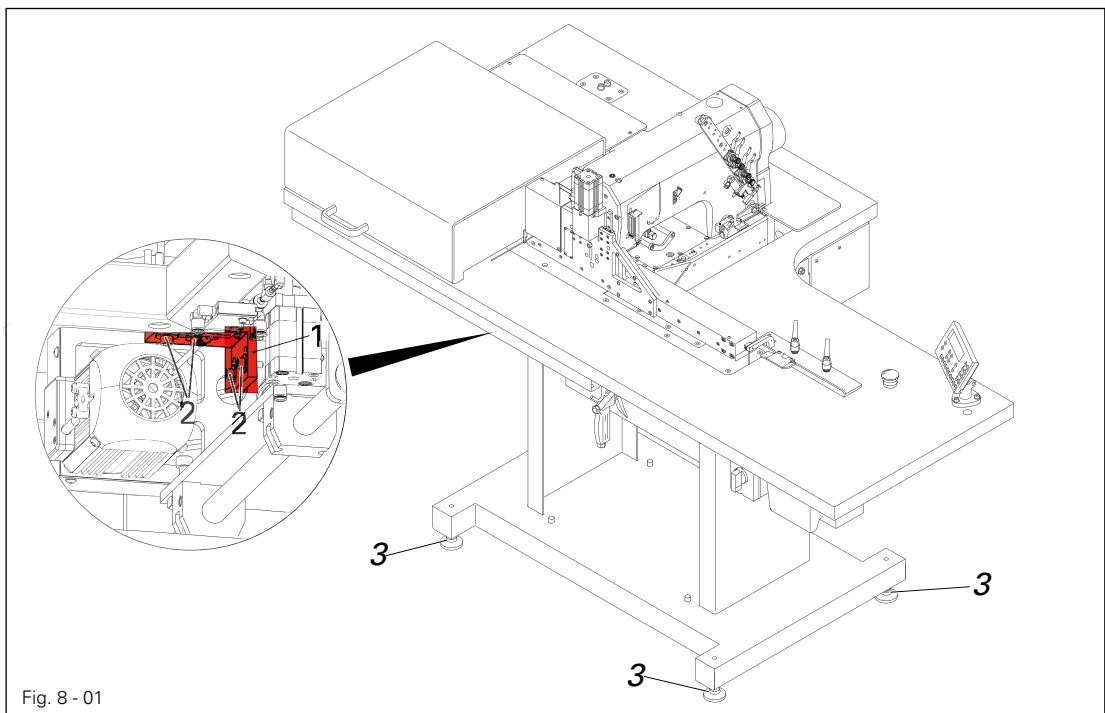

- Loosen the adjustable feet **3**.
- Align the machine horizontally by turning the levelling feet.



All four levelling feet must sit firmly on the ground.

- Tighten the lock nuts on the levelling feet **3**.
- Remove transit support **1** (screws **2**).



Remove transit support **1** (screws **2**) before initial commissioning!

8.01.02 Mounting the reel stand

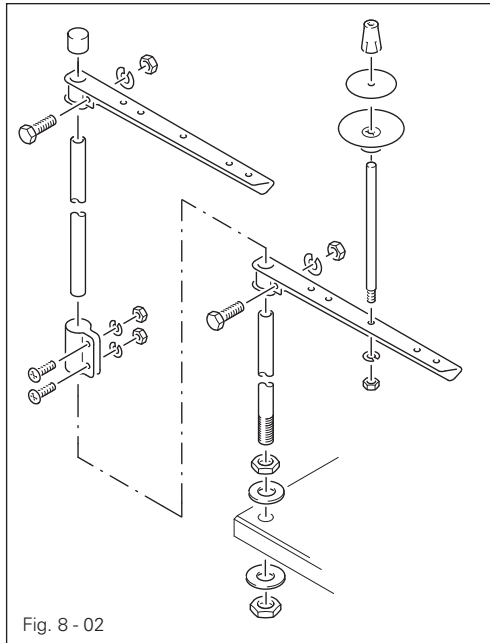

- Assemble the reel stand as shown in Fig. 8 - 02.
- Then insert the stand into the hole in the table top and secure it with the enclosed nuts.

8.02 Connecting the plug-in connections and ground cable

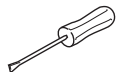
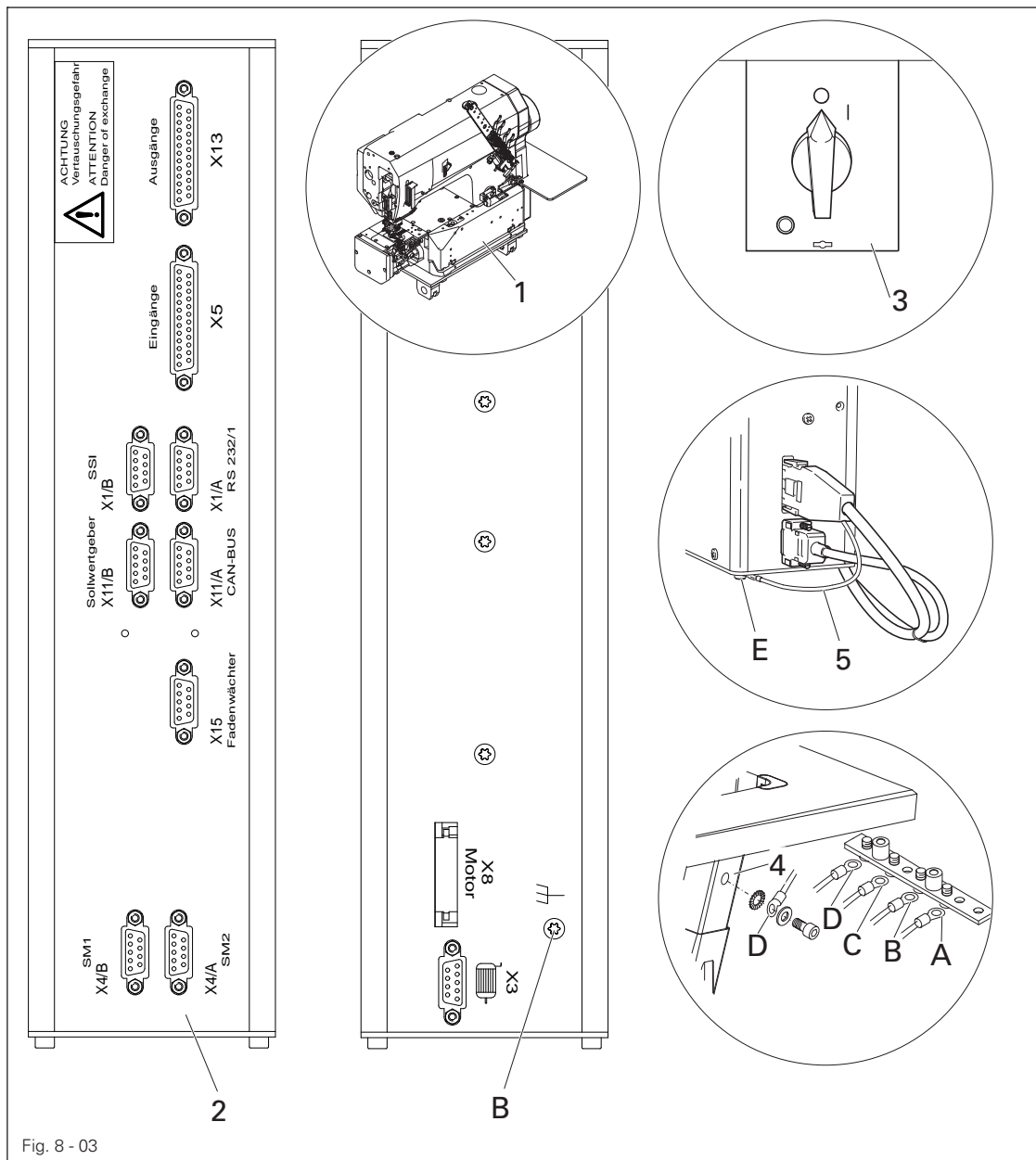

- Insert all plugs on the control box 2 in accordance with their designation.
- Insert the "motor" into the bushing X 3 and the bushing X 8.



Caution!

Plugging in the connector incorrectly can damage the control unit!

- Attach the following ground cables in order to discharge static electricity:
- Securely attach the ground cable from the sewing head 1 to ground point A.
- Securely attach the ground cable from the control point 8 to ground point B.
- Securely attach the ground cable from the main switch 3 to ground point C.
- Securely attach the ground cable from the stand 4 to ground point D
- Securely attach the ground cable 5 from the motor to ground point E

8.03 Initial start-up

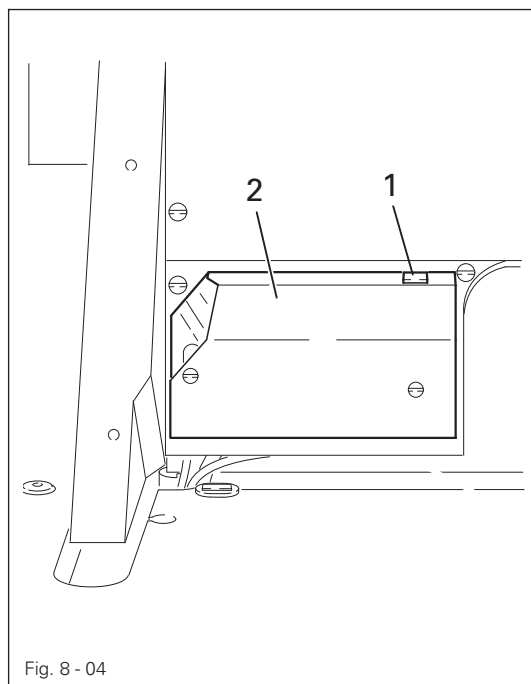

- Inspect the machine and in particular the electric lines and pneumatic connecting hoses for possible damage.
- Remove the stopper 1 from the oil tank 2. The stopper serves solely for transit support and may not be used during the sewing operations.
- Clean the machine thoroughly and then oil it, see Chapter 10 Maintenance and Care.
- Have technical staff check whether the machine's motor may be operated at the existing mains voltage.



Never operate the machine if there are any differences.



Before the initial commissioning, have technical staff verify that parameter 201 (machine class) is set to "1".



The machine must only be connected to a grounded socket!

- Connect the machine to the compressed air system. The manometer should display a pressure of around 6 bar. Set this value, if possible (see Chapter 10.04 Monitoring/adjusting air pressure).

8.04 Switching the machine on/off

- Switch the machine on, see Chapter 7.01 Main switch.

9

Set-up



Observe and comply with all regulations and instructions in this instruction manual.

Pay particular attention to all safety regulations!



All set-up work may only be carried out by appropriately instructed personnel. Disconnect the machine from the electricity mains for all set-up work by operating the main switch or by removing the mains plug!

9.01

Inserting the needle

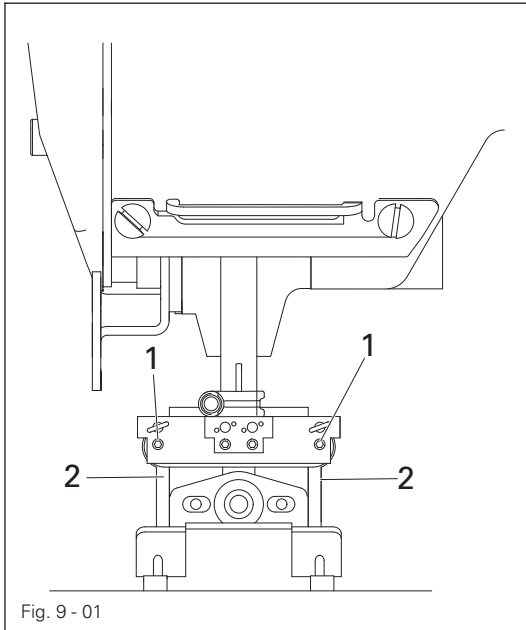

Switch off the machine!

Risk of injury due to accidental machine start-up!



Only use needles of the system intended for the machine, see **Chapter 3 Technical Data!**

- Approach the thread-in position (see P. 18)
- Bring the needle bar to the top position and loosen screw 1.
- Insert needle 2 up to the stop (while doing so, the long needle groove must point to the right).
- Tighten the screws 1.

9.02 Threading the needle / adjusting the needle thread

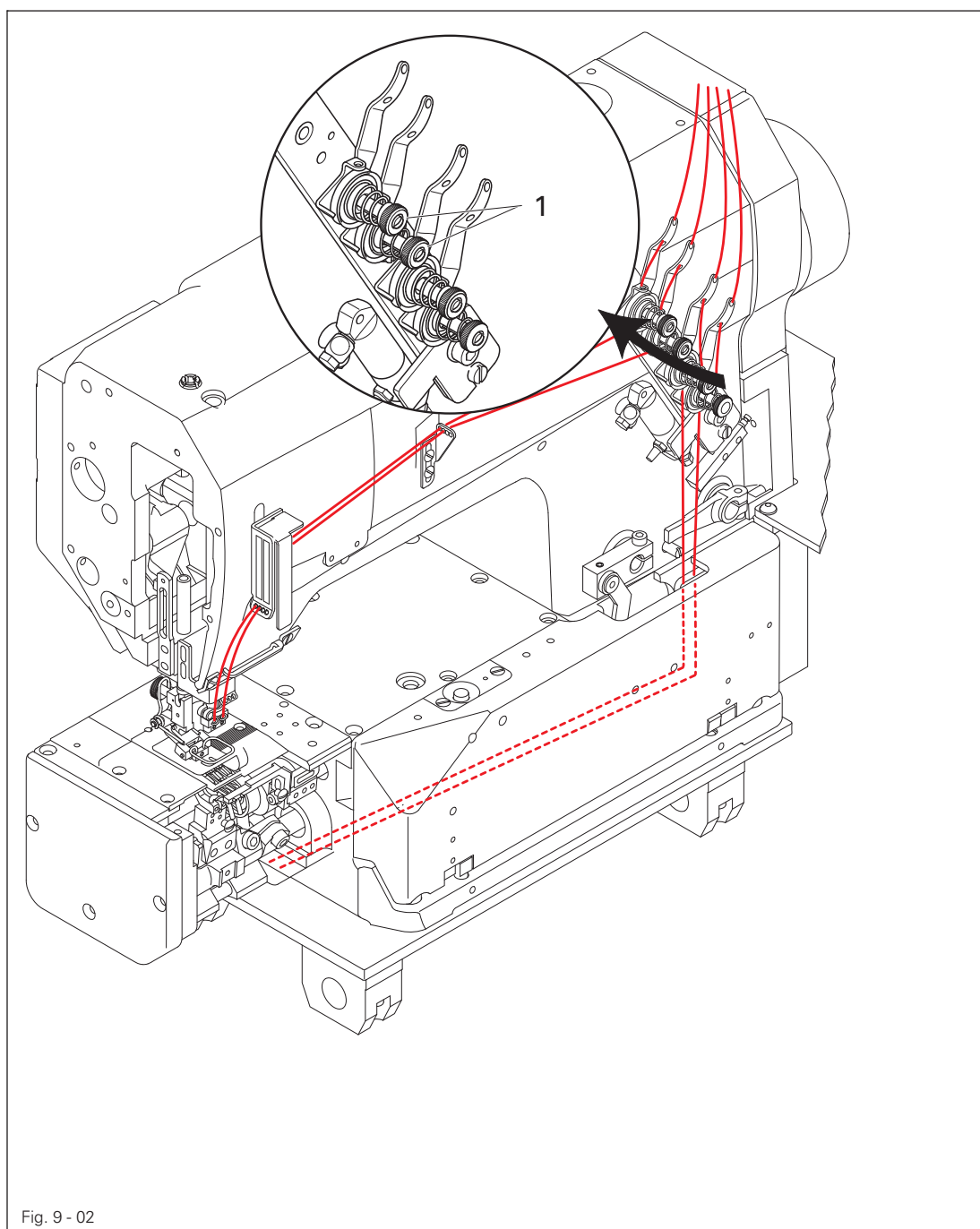

Switch off the machine!
Risk of injury due to accidental machine start-up!

- Thread the needle as shown in Fig. 9-02.
- Adjust the needle thread tension by turning the knurled thumb screw 1.

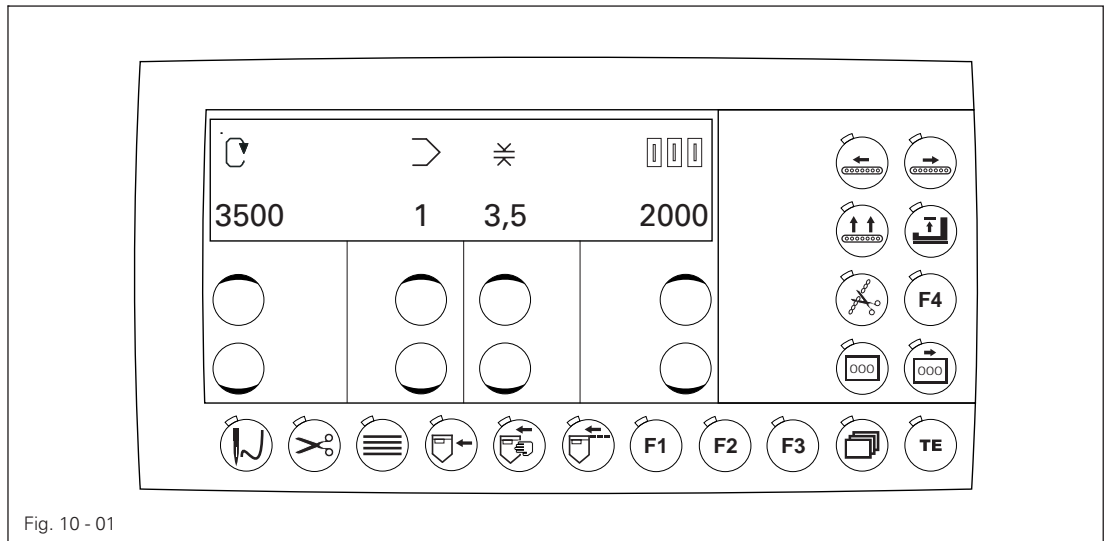

Fig. 10 - 01

The following appear on the display (from the left):

- Max. speed (e.g. 3500 revolutions per minute), it can be changed using the corresponding plus/minus key. Coded via parameter 809.
- Stitch length (e.g. 3.5 mm), it can be changed using the corresponding plus/minus key. The electronically set stitch length here must be identical to the mechanically set stitch length on the sewing head.
- The following procedure should be observed to set the stitch length:
 1. Set the mechanical stitch length on the sewing head.
 2. Enter the electronic stitch length.
 3. Feed in the pocket blank(s) and check the stitch quality.
 4. Change the mechanical and/or electronic stitch length if the sewn pocket blank is too flat. Coded via parameter 810.
- Piece counter or counter (e.g. 20000). Coded via parameters 811 and 812.

The function of the other keys is explained in the “Operating Controls” chapter. The sewing cycle is started by inserting pocket blanks.



ERROR 6 appears if the sewing head is not in the sewing position after switching on the unit. The outputs to raise the band feed and move the sewing head are not switched on (valves stay depressurised) and the user must manually move the sewing head to the sewing position.

10.01 Sewing – automatic mode



The following work steps assume that the sewing preparations listed in the “Set-up” chapter have been carried out thoroughly and the machine has been programmed according to the order.



- Turn on the machine at the main switch and wait for it to be ready for operation.
- Press the presser foot key and raise the presser foot.
- Lay the top edge of the pocket blank at the stop.
- Slide the pocket blank to the left under the Plexiglas cover.
- Light barrier detects the start of the pocket blank.
- Feed band takes hold of the pocket blank.
- Feed band moves the pocket blank to the left into the pleating attachment.
- Pleating attachment folds over the top edge.
- Feed band moves the folded pocket blank into the sewing position.
- Top edge seam is sewn.
- Pocket blank is transported out of the sewing area.



The following keys are switched on in automatic mode, see Fig. 10-02

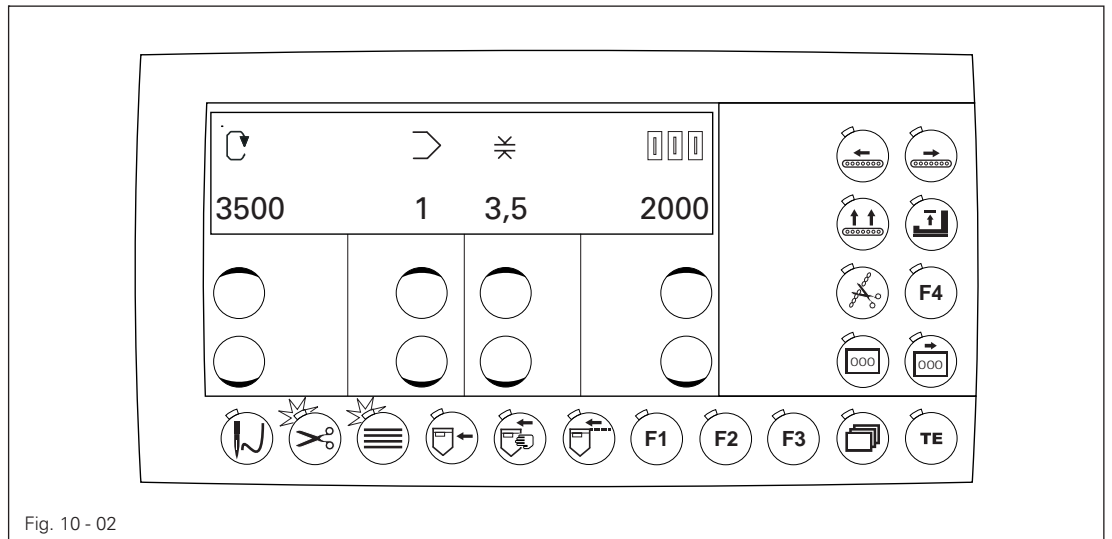

Fig. 10 - 02

10.02 Sewing – Unit with cutter and rack



In contrast to the basic machine described in 10.01, the “Plus” machine separates the pocket blanks after hemming with a cutter. An integrated extraction device removes the loose threads during the cutting process and collects them in a container under the work table. The individual pocket blanks are automatically fanned out with an automatic racking device and placed on a round table.



- Turn on the machine at the main switch and wait for it to be ready for operation.
- Press the presser foot key and raise the presser foot.

- Lay the top edge of the pocket blank at the stop.
- Slide the pocket blank to the left under the Plexiglas cover.
- Light barrier detects the start of the pocket blank.
- Feed band moves the pocket blank to the left into the pleating attachment.
- Pleating attachment folds over the top edge.
- Feed band moves the folded pocket blank into the sewing position.
- Top edge seam is sewn.
- Pocket blank is transported out of the sewing area.
- Light barrier triggers the “Cutting” process.
- Pneumatically operated blade separates the continuing seam.
- Feed band transports the pocket blank to the rack.
- Rack moves back and opens the passage downwards.
- Pocket blank falls down onto the round table.
- Pneumatic cylinder switches the round table one step further.
- Rack moves forward and closes the passage.
- Unit is ready for the next pocket blank.
- The blanks can be removed when the round table is full.

10.03 Input mode

- Select the function group

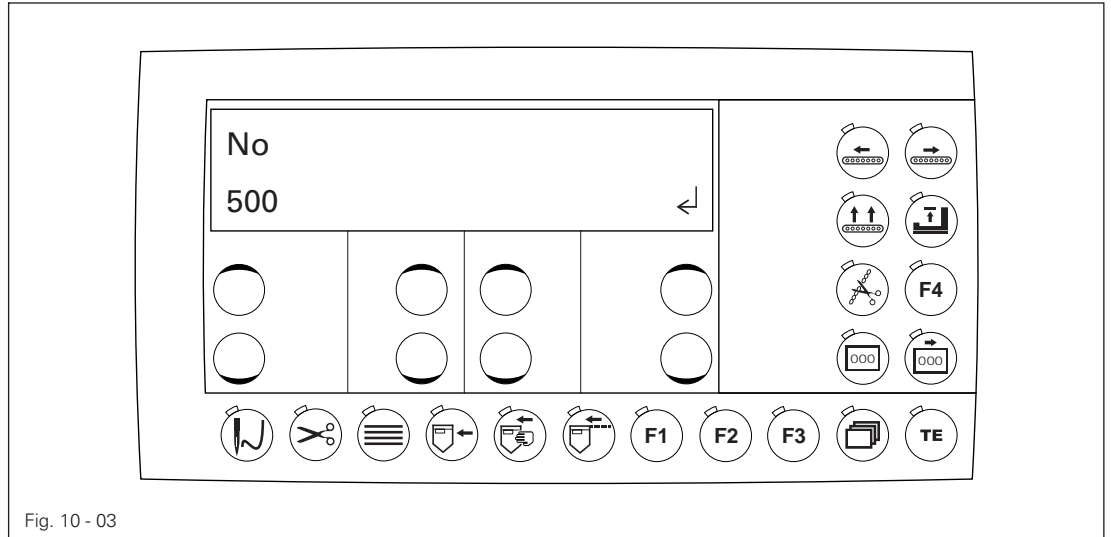

Fig. 10 - 03

The desired function group must be selected using the allocated plus/minus key after changing to input mode.



Select the function group or function with the corresponding plus/minus key.



The upper key is + and the lower key is -.



The selected function group is taken over by pressing the plus/minus key under the Enter symbol and the machine jumps to the "Enter parameter" status after entering the code. This display does not appear if the access code has already been entered or the function group is not code protected.



If the TE key is pressed, the machine changes to production mode (LED off).

- The following function groups are available:

Group	Function	Access rights (factory setting)
100	Operator level	free
200	Mechanic level	coded
300	Sewing drive positions	coded
400	Times	coded
500	Counter and speeds	coded
600	Service	coded
700	Sewing motor	coded
800	Access rights	coded

Access rights for the individual function groups and for the functions accessible via the keys can be changed in the function group **800**. The access code for coded functions can also be changed (status on delivery: **3819**). Coded functions can only be accessed after entering the code. Specific keys as interpreted as numeric keys for input purposes (see the “Operating Controls” chapter).

10.04 Input mode

- Enter parameters

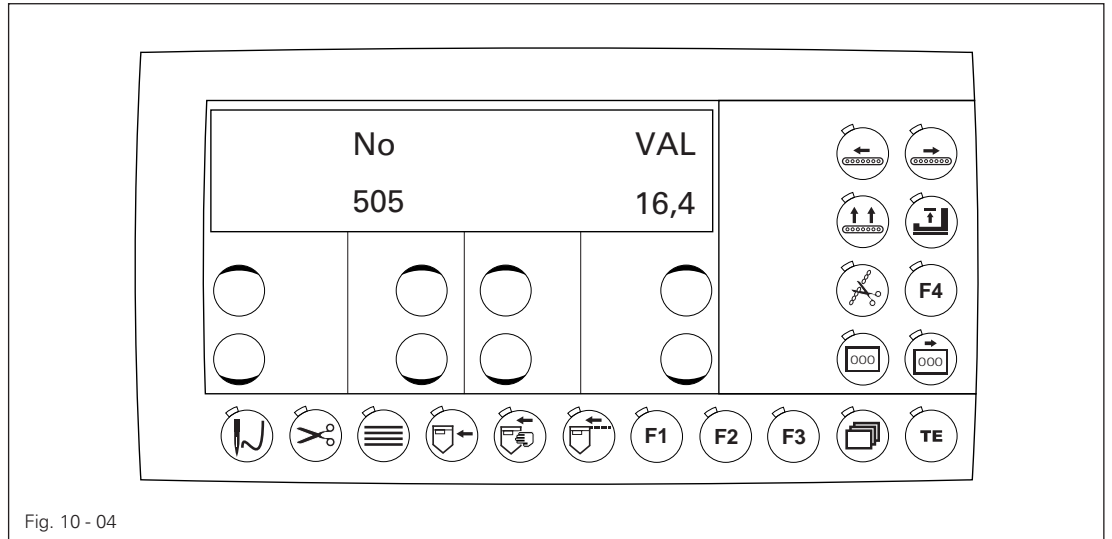

Fig. 10 - 04

The display shows the selected parameter number on the left and the associated parameter value further to the right. Parameter **505**, the clearance from the chain cutter sensor to the chain cutter has been selected in the example above. The displayed parameter value is **16.4 mm**.



The values above can be changed using the plus/minus keys. The parameter values are taken over by advancing to another parameter number.



If the TE key is pressed, the values are also taken over and the machine switches to sewing mode.

10.09 Parameter list

Function group 100:	Operator level
101	Display software version (0437/xxx)
102	Display motor control software version
103	Key beeper (I = OFF, II = ON)
104	Needle thread monitor (I = OFF, II = ON)
105	Bobbin thread monitor (I = OFF, II = ON)
106	Display serial number of machine
Function group 200:	Mechanic level
201	Subclass(x)
	1: 3538-1/01 (Basic) 2: 3538-1/02 (with chain cutter) 3: 3538-1/03 (with chain cutter and stacker)
202	Label feeder attached (I = OFF, II = ON)
203	Band feed acceleration (200; 50 – 999)
204	Band feed braking (250; 50 – 999)
205	Maximum stitch length when sewing in 1/10 mm (4.0; 2.0 – 8.0)
206	Switching frequency from fine step to full step (375; 0 – 2000)
207 ^(2,3)	Automatic extraction (I = OFF, II = ON)
Function group 300:	Positions
301	Reference position (needle at top edge of needle plate)
302	Position of cover-thread carrier t.d.c. (153, 0 – 191)
303	Position of needle at bottom position (81, 0 – 191)
Function group 400:	Times (0.01 – 2.00 s)
401	Holdoff time after initial light barrier (0.01 s)
402	Switching time for needle head to move to thread-in position (A7) (1.00 s)
403	Wait period after sensor when sewing head in sewing position (A7) (0.10 s)
404	Switching time to raise/lower band feed (A6) (0.85 s)
405	Switching time of presser foot upwards (A10) (0.20 s)
406	Switching time of presser foot downwards (A10) (0.20 s)
407	Needle thread monitor hide stitches (3, 0 – 9)
408	Bobbin thread monitor hide stitches (3, 0 – 9)
409 ^(2,3)	Chain cutter switch-on time (A8) (0.01 s)

410 ^(2,3)	Chain cutter travel time downwards (A8) (0.01 s)
411 ⁽³⁾	Switching time of stacker downwards (A12) (0.01 s)
412 ⁽³⁾	Switching time of stacker upwards (A12) (0.01 s)
413 ⁽³⁾	Switching time of stacker to the right (A13) (0.01 s)
414 ⁽³⁾	Switching time of stacker to the left (A13) (0.19 s)
415 ⁽³⁾	Switching time to open stacker (A14) (0.28 s)
416 ⁽³⁾	Switching time to close stacker (A14) (0.17 s)
417 ⁽³⁾	Switching time to turn stacker (A4) (0.01 s)
418 ⁽³⁾	Switching time to hold pocket (A3) (0.01 s)
Function group 500:	Counter, speeds and clearances
501	Soft start stitches (0; 0-15) soft start speed (1500; 0 – 4500 rpm)
502	Stop clearance (55.0; 0 – 999.9)
503	Length when filling machine (370; 0 – 9999)
504	Speed of band feed in a manual process (like a sewing head speed with a stitch length of 4 mm) (2000, 10 – 4000)
505 ^(2,3)	Clearance of chain cutter sensor to the chain cutter (16.4; 0 – 999.9)
506 ^(2,3)	Clearance of start of pocket to the chain cutter (3.0; 0 – 999.9)
507 ^(2,3)	Clearance of end of pocket to the chain cutter (3.0; 0 – 999.9)
508 ⁽³⁾	Clearance of stacker sensor to the stacker (90.0; 0 – 999.9)
Function group 600:	Service
601	Band feed stepping motor process (X: individual steps, XX: continuously forwards or backwards while the key is pressed)
602	Inputs: 0123456789ABCDEF
	0: free (E1 – X5.1)
	1: free (E2 – X5.2)
	2: free (E3 – X5.3)
	3: free (E4 – X5.4)
	4: free (E5 – X5.5)
	5: free (E6 – X5.14)
	6: free (E7 – X5.15)
	7: Needle thread monitor (option) (E8 – X5.16)
	8: Bobbin thread monitor (option) (E9 – X5.9)

	9: Stacker cover (E10 – X5.10) (3)
	A: Feed band stop (E11 – X5:11)
	B: Stop switch (break contact) (E12 – X5.12)
	C: Sewing head in sewing position (E13 – X5.13)
	D: Stacker light barrier (E14 – X5.8) (3)
	E: Chain cutter light barrier (E15 – X5.6) (2.3)
	F: Initial light barrier (E16 – X5.7)
603	Outputs:
	1: free (X13.1 and X13.2)
	2: free (X13.3 and X13.4)
	3: Presser foot (X13.5) (1: top, 0: bottom)
	4: Raise band feed (X13.6) (1: top)
	5: Lower band feed (X13.7) (1: bottom)
	6: Sewing head sewing position (X13.8)
	7: Sewing head thread-in position (X13.9)
	8: Open thread tension (X13.10)
	9: Extraction (X13.11) (1: on, 0: off) (2.3)
	10: Stacker left/right (X13.12) (1: left, 0: right) (3)
	11: Stacker down (X13.13) (1: bottom, 0: top) (3)
	12: Open stacker (X13.25) (1: open, 0: closed) (3)
	13: Hold pocket (X13.24) (3)
	14: Turn stacker (X13.16) (3)
	15: Chain cutter (X13.17) (1: on, 0: off) (2,3)
	16: Sewing motor running (X13.18) (1: running, 0: at a standstill)
604	Turn sewing motor in sewing direction
605	Run cold start
606 ³	Run stacking process
Function group 700:	Sewing motor
701	P-section speed regulator (10)
702	I-section speed regulator (50)
703	P-section position controller (20)
704	D-section position controller (30)
705	Time for position controller (25)
706	P-section position controller for rest brake (25)
707	D-section position controller for rest brake (15)
708	Maximum torque for rest brake (0)
709	Minimum machine speed (6)
710	Maximum machine speed (4500)

711	Maximum motor speed (68)
712	Positioning speed (25)
713	Acceleration ramp (35)
714	Braking ramp (30)
715	Reference position (43)
716	Dead man time (40)
717	Motor starting current (7)
718	Anti-rank filter (3)
719	Rotation direction assignment (1)
720	Positioning technique (1 – time-optimised; 2 – path-optimised)
Function group 800:	Access rights
801	Access rights for function group 100*
802	Access rights for function group 200*
803	Access rights for function group 300*
804	Access rights for function group 400*
805	Access rights for function group 500*
806	Access rights for function group 600*
807	Access rights for function group 700*
808	Access rights for function group 800*
809	Access rights for maximum key speed*
810	Access rights for stitch length keys*
811	Access rights for piece counter key*
812	Access rights for counter key*
813	Access rights for direct functions* (band forwards, band backwards, raise band, presser foot up/down and chain cutter)
821	Enter access code (in status on delivery: 3538)

* 0 – free, 1 – blocked with a code

10.10 Error messages

Error code	Description
Error 1	System error
Error 2	Sewing motor ERROR 2/BB/xxx
BB =	20: Deadman
	10: Speed
	0B: StopX
	0A: Reset stitch counter
	09: Write parameters
	05: Position t.d.c. by shortest route
	03: Position t.d.c. in reverse
	02: Position t.d.c. forwards
	30: Timeout for increasing speed
	31: Timeout from uncertain positioning
	32: Timeout from deadman command
	33: Timeout for deleting errors
	34: Timeout for emergency stop
	35: Timeout for writing parameters
	36: Timeout for resetting stitch counter
	37: Timeout for stop command after x stitches
	38: Timeout for initialisation
xxx = sewing motor control unit error (see Motor errors)	39: Establishing contact when turned on
Error 3	Ramp memory too small
Error 4	free
Error 5	Stacker not ready(3)
Error 6	Sewing head sewing position/thread-in position (sensor monitoring)
Error 7	Stepping motor movement
	1. Ramp X not ready
	2. Ramp Y not ready
	3. Time monitoring
Error 8	Needle thread monitor
Error 9	Bobbin thread monitor
Error 11	Stepping motor step frequency too high
Error 21	Power supply unit overloaded (24 V)
Error 22	Mains voltage
Error 23	Power supply 24 V too low

Motor errors

Error code	Description
33	Invalid parameter value
35	Communication error
36	Init. not ready
37	Command overrun
64	Mains off during initialisation
65	Excess current directly after mains on
66	Short circuit
68	Excess current during operation
70	Motor blocked
71	No incremental plug
74	Incremental encoder missing for transmission/ reduction
173	Motor blocked in 1st stitch
175	Internal starting error
222	Dead man monitoring

11 Maintenance and Care

11.01 Maintenance intervals

Cleaning the hook area	daily, several times during continuous operation
Cleaning the complete machine	weekly
Machine oil level	daily, before start-up
Checking / setting the air pressure	as needed
Cleaning the maintenance unit air filter	as needed

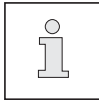

These maintenance intervals are based on an average running time of a single shift production shop. Shorter maintenance intervals are recommended for increased running times.

11.02 Cleaning the machine



The required cleaning cycle for the machine depends on the following factors:

- Single or multi-shift operation
- Dust formation caused by the workpieces

Optimal cleaning instructions can therefore only be determined on a case-by-case basis.



Disconnect the machine from the electricity mains for all cleaning work by shutting off the main switch or removing the mains plug! Risk of injury due to accidental machine start-up!

The following tasks are recommended during a single shift operation to avoid operational errors:

- Open the hook area cover.
- Clean the hook area daily, more frequently during continuous operation.
- Close the gripper area cover!



Only operate the machine when the hook room cover is closed!
Risk of injury due to moving parts!

11.03 Checking / topping up the oil level of the oil tank for the front parts

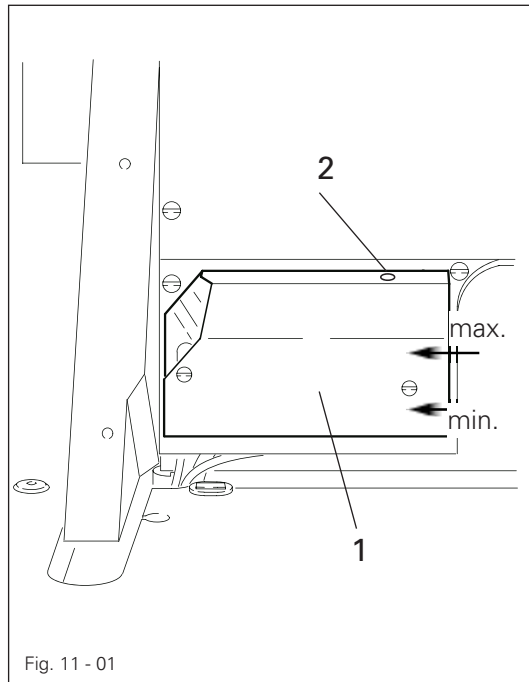

Check the oil level before every start-up.

The oil level must not drop below the "min." marking or rise above the "max." marking.

The oil level must always be visible in the sight glass 1.

- Add oil to the container through the hole 2 as needed



Only use oil with a centre viscosity of 22.0 mm²/s at 40 °C and a density of 0.865 g/cm³ at 15 °C.

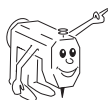

We recommend PFAFF sewing machine oil part no. 280-1-120 144.

11.04 Checking / topping up the oil level of the gear mechanism

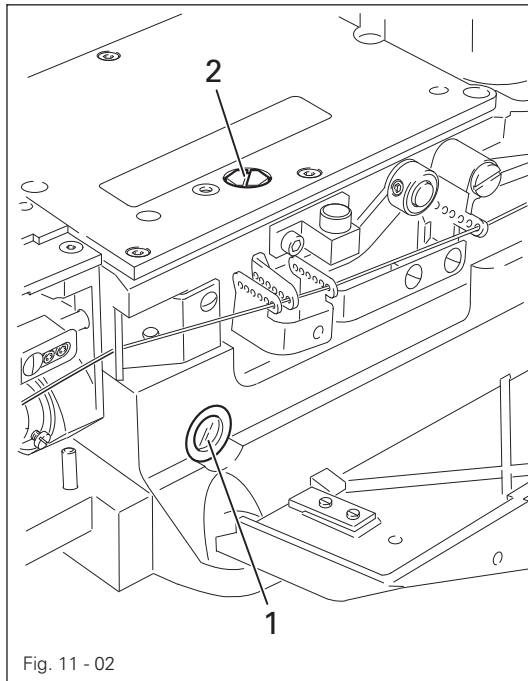

Switch off the machine!
Risk of injury due to accidental machine start-up!



Open the side cover and check the oil level before every machine start-up.
The oil level must always be visible in the sight glass 1 (if no air bubble is visible, then the oil level is too high.)

- Remove the screw 2 as needed and add only enough oil for an air bubble to remain visible.
- Replace the screw 2.



Only use oil with a centre viscosity of $22.0 \text{ mm}^2/\text{s}$ at $40 \text{ }^\circ\text{C}$ and a density of 0.865 g/cm^3 at $15 \text{ }^\circ\text{C}$.



We recommend PFAFF sewing machine oil part no. 280-1-120 144.

11.05 Checking / setting the air pressure

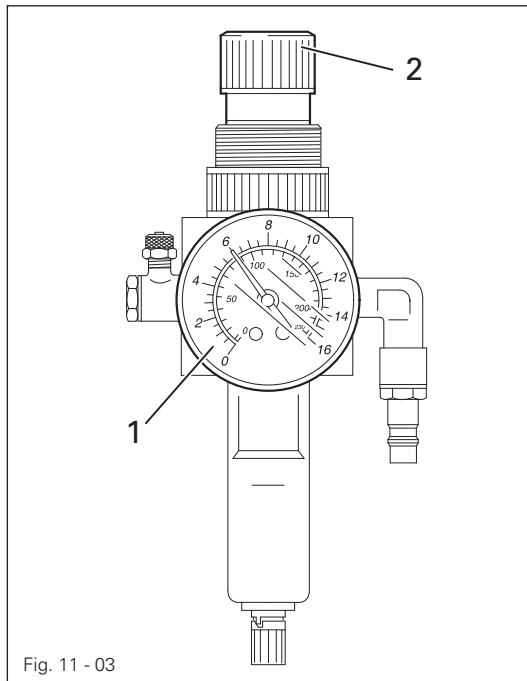

Fig. 11 - 03

- Check the air pressure on the manometer 1 before every start-up.
- The manometer 1 must show a pressure of 6 bar.
- Adjust this value if needed.
- Pull up the button 2 for this and turn it out of position accordingly.

11.06 Emptying / cleaning the maintenance unit's water tank

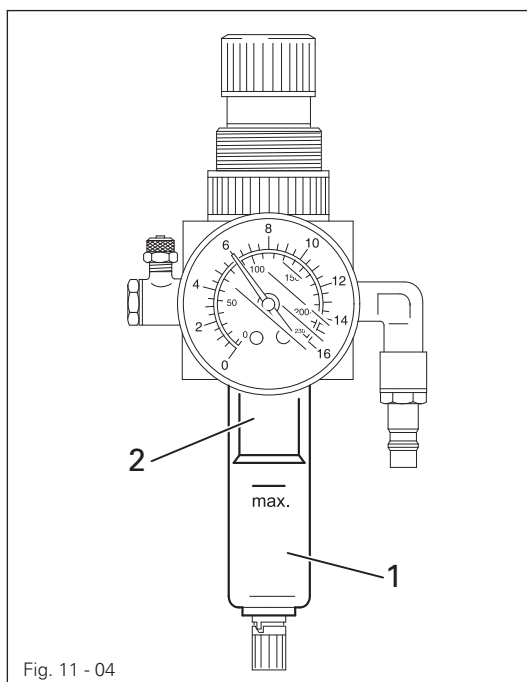

Fig. 11 - 04



Switch the machine off.
Detach the compressed air tube on the maintenance unit.

Empty the water tank

- The water tank 1 empties itself automatically after the compressed air tube for the maintenance unit has been removed.

Clean the filter

- Unscrew the water tank 1 and take out the filter 2.
- Clean the filter with compressed air or isopropyl alcohol, part number 95-665 735-91.
- Screw in the filter 2 and screw on the water tank 1.

12 Wearing Parts

This list shows the most important wearing parts.

A detailed parts list for the complete machine can be downloaded at www.pfaff-industrial.de/de/service-support/downloads/technical.

As an alternative to the Internet download, the parts list can also be requested as a hard copy under order no. **296-12-19 292**.

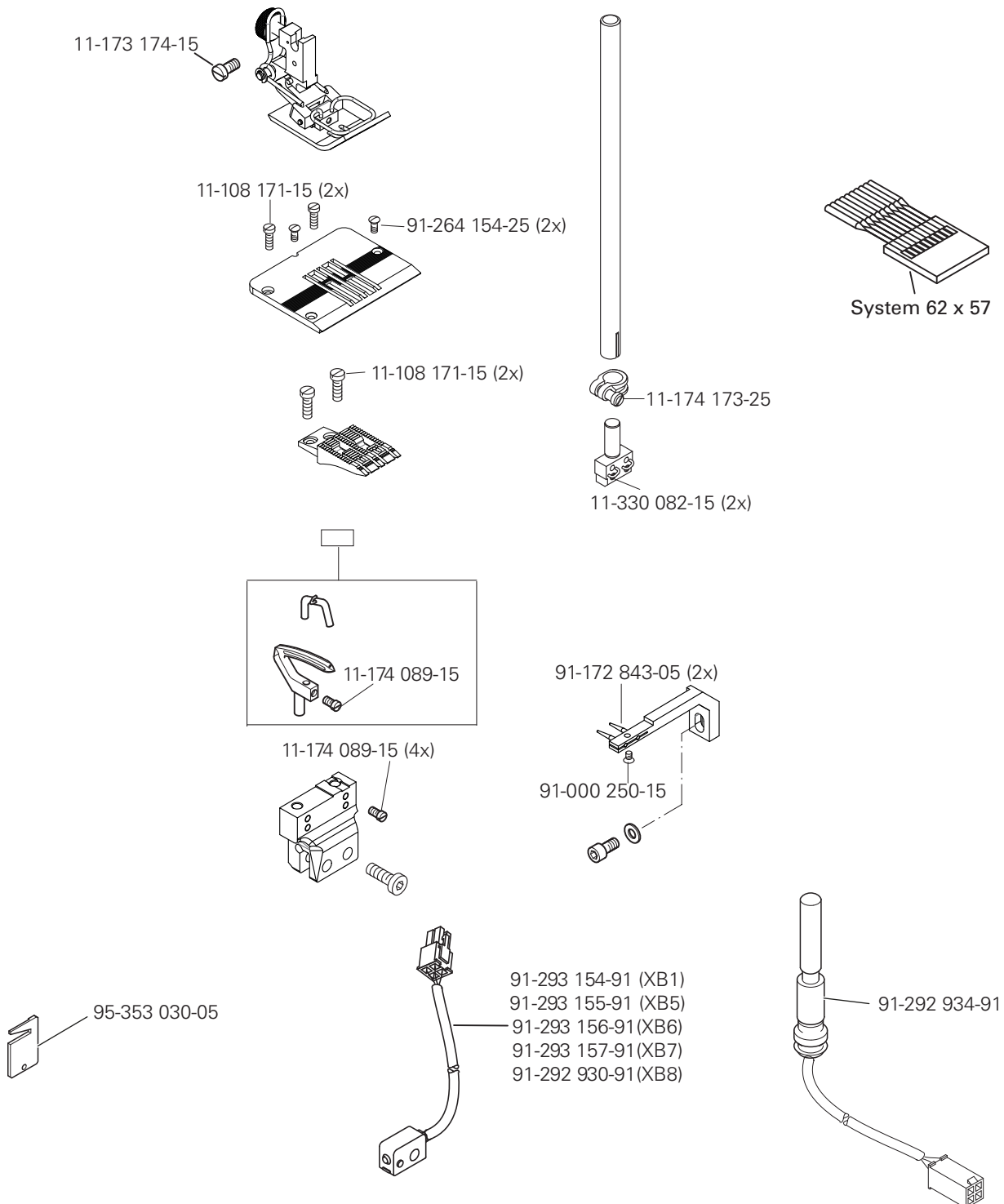



Europäische Union
Wachstum durch Innovation – EFRE

PFAFF Industriesysteme und Maschinen GmbH

Hans-Geiger-Str. 12 - IG Nord
D-67661 Kaiserslautern

Telefon: +49-6301 3205 - 0

Telefax: +49-6301 3205 - 1386

E-mail: info@pfaff-industrial.com